



## Brontes-IS Colorimeter Operating Manual.







All rights reserved. No part of this document may be reproduced, stored in a database or retrieval system, or published in any form or way, electronically, mechanically, by print, photo print, microfilm or any other means without prior written permission from the publisher.

All correspondence regarding copyrights :

Admesy B.V.

Beneluxstraat 7

6014CC Ittervoort

The Netherlands

Tel : +31 (0) 475 600232

Fax : +31 (0) 475 600316

URL : <http://www.admesy.nl>

# Contents



1	About this manual	5
2	General introduction	6
	2.1 Colorimeter highlights	6
	2.2 Standards	6
3	Electrical interfaces	7
	3.1 USB interface	7
	3.2 RS232 interface	7
	3.3 GPIO interface	8
	3.3.1 Triggering	9
	3.3.2 I/O	9
	3.4 Power connections	10
4	Communications protocol	11
	4.1 USB	11
	4.2 RS232	11
5	Device drivers	12
	5.1 USB	12
	5.2 RS232	12
6	Command set description	13
	6.1 Command structure	14
	6.2 System commands	15
	6.3 Configuration commands	16
	6.4 Measurement commands	18
	6.5 User EEPROM commands	19
	6.6 Returned results	20
7	Measurement example	21
8	Brontes-IS formulas.	22
	8.1 XYZ to Yxy conversion	22
	8.2 XYZ to CIE 1976 UCS Yu'v' conversion	22
	8.3 XYZ to Luminous flux	22
	8.4 XYZ to Luminous intensity	22
9	Operating modes	23
10	Typical spectral sensitivity	24
11	Mechanical drawing (mounting holes)	25

# 1 About this manual

The material in this manual is subject to change. No rights can be derived from the content of this manual.

The content of this manual is valid for firmware version higher or equal than 1.01.

In this manual, the following symbols are used to draw your attention.

-  : Practical tip
-  : Note



## 2 General introduction

The Brontes-IS colorimeter is a member of the Admesy Cyclopes series colorimeters. The Brontes-IS colorimeter offers a unique combination of high speed and accurate colour measurement. Our products are developed with the highest care for usability and robustness of both hardware and software.

### 2.1 Colorimeter highlights

Colour measurement in XYZ, Yxy, Yu'v', Luminous flux and Luminous intensity.

Other colour spaces available via a supplied colour library.

High speed colour sampling at 10k Samples/s, Luminance at 25K Samples/s.

USB/RS232 communication interfaces.

General purpose I/O (3.3V) with trigger input and output.

Stand alone usage with Go-NoGo option through GPIO.

### 2.2 Standards

The colorimeter is compliant to the USBTMC standard and can be used in combination with external provided USBTMC compliant drivers.

Currently it has been tested on Windows, Linux and Apple OSX using NI VISA (<http://www.ni.com/visa>)

and using the open source driver provided by Agilent

([http://www.home.agilent.com/upload/cmc\\_upload/All/usbtmc.html](http://www.home.agilent.com/upload/cmc_upload/All/usbtmc.html)) on Linux (i686, x86\_64 and ARM).

For installation instructions on the Agilent USBTMC driver, refer to the Linux Brontes howto on the Admesy web site ([http://www.admesy.nl/products/docs/Admesy\\_Brontes\\_Linux\\_howto.pdf](http://www.admesy.nl/products/docs/Admesy_Brontes_Linux_howto.pdf)).

### 3 Electrical interfaces



#### 3.1 USB interface

The USB mini B connector is used to connect the Brontes-IS Colorimeter to a PC/Laptop. This is the preferred connection method for the Brontes-IS Colorimeter because of speed.

The Brontes-IS Colorimeter complies to the USBTMC class protocol and can therefore be used directly with third party provided VISA compliant libraries like NI-VISA .

#### 3.2 RS232 interface

RS232 is provided to connect the Brontes-IS Colorimeter to any host that doesn't provide USB or for which no USBTMC drivers exist. Using RS232 the high speed options of the colorimeter are still available, only transfer of data to the host is reduced in speed. It is recommended to use USB in case the high speed sampling options are needed.

**i** The USB cable should not be connected together with the RS232 cable.

The following table shows the RS232 port configuration.

Baud rate	Data bits	Parity	Stop bits	Flow control	Termination character
115200	8	None	1	None	LF = '\n'

Table 1: RS232 port configuration



### 3.3 GPIO interface

The general purpose IO can be used for the following functions :

- Triggering the Brontes-IS colorimeter from an external source.
- Trigger an external device using the trigger output
- Output results to an external source from the Brontes colorimeter (Go -NoGO operation).

The GPIO provides one trigger input, four digital outputs and and I<sup>2</sup>C communication port.

Brontes backside view

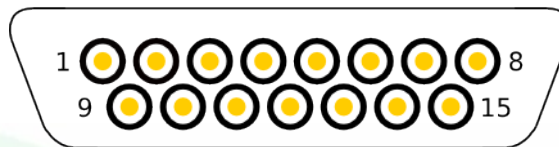

GPIO pin layout

Pin	Function	Molex-Socket with lead (0834229018) Cable colour
1	9V input	Black
2	I/O 4	Brown
3	I/O 3	Red
4	I/O 2	Orange
5	I/O 1	Yellow
6	Trigger output	Green
7	I/O 5	Blue
8	Trigger input	Purple
9	Not connected	Grey
10	GND	White
11	GND	Black-white
12	D+ (USB)	Brown-white
13	D- (USB)	Red-white
14	VBUS (USB)	Orange-white
15	GND	Yellow-white

**⚠** The USB connections on the GPIO are meant for applications where the standard USB-B connector does not provide enough mechanical robustness. They should never be used together with the USB-B connector.

The 9V input (pin 1) can be used together with GND (pin 10,11,15) to provide power to the Brontes-IS colorimeter.

When using this power connection, please refer to the power supply table on the next page.

**i** Be careful to not short the 9V supply with any other pins. The I/O pins are only protected up to 5.8V.

### 3.3.1 Triggering

The Brontes-IS can be triggered when it's operating in USB, RS232 or stand alone mode. In stand alone mode, the configured measurement will be carried out once a trigger arrives and the result will be output via the digital I/O channels on the GPIO connector. When triggering is enabled, the trigger output line will be set to a high level once the measurement has finished and the measurement result is available.

The trigger output will stay at a high value for a minimum of 100µs in stand alone mode. In USB and RS232 it will stay at a high level until the next command is carried out.

In USB, a trigger will carry out the previously send command and send the result to the host via an interrupt endpoint on the USB bus. The colorimeter main application allows external triggering in the datalogging tab. Supplied code examples show how to use this feature in an application.

In RS232 mode, the trigger output line is used to indicate that the measurement is ready.

Trigger signals can be either edge or level triggered and should comply to the following diagram.

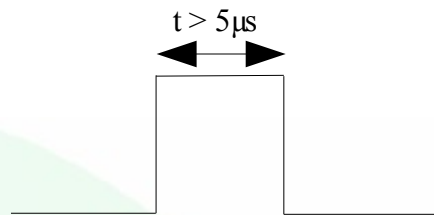

Trigger pulses arriving faster than the Brontes-IS can measure will be ignored, but it may slowdown overall performance. Trigger pulses should not arrive faster than the measurement takes to complete.

Triggering via USB currently only supports the :MEASure commands. This means that it is not supported to trigger :SAMPlE commands.

The output trigger is made zero before a command starts and made high after the command finishes. The minimum pulse time is 50µs for the trigger output.

### 3.3.2 I/O

The GPIO can be used in stand alone mode and directly controlled via PC software. When operating in stand alone mode, the I/O is used to output the result of a measurement.

### 3.4 Power connections

The Brontes-IS colorimeter should be connected to either powered USB or using a 9V DC power supply.

When using RS232 the colorimeter needs to be powered via the external adapter.

In case a 9V adapter is used, Admesy can only guarantee stable measurement results and CE compliance when using the supplied adapter.

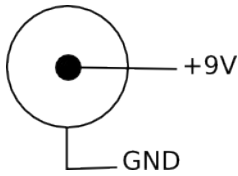

The unit shall be powered by a 9Vdc voltage or via a standard USB PC-port, reinforced separated from Mains, with a limited energy of < 150VA and < 8A.

When stable mounting is needed, the GPIO power input pins (pin 1 & pin 10,11,15) can be used to supply power to the Brontes-IS colorimeter.

For power ratings, please refer to the power supply table on the next page.

	Min voltage	Typical voltage	Max voltage	Consumption
USB powered	4.75V	5.00V	5.25V	Typical 50-60mA
DC-adapter powered	8.50V	9.00V	15.00V	Typical 50-60mA
GPIO powered	8.00V	9.00V	15.00V	Typical 50-60mA

*Table 2: Power supply table*

## 4 Communications protocol

### 4.1 USB

The Brontes-IS colorimeter can be connected to any USB host that runs Windows, Linux or Apple OSX. The colorimeter is a USBTMC compliant device. This makes the Brontes-IS colorimeter directly usable in programming languages like NI's Labview and Labwindows or any other language that supports USBTMC.

The Brontes-IS colorimeter has two interfaces build in, which require a different device driver to be used.

Firmware updater (USB RAW device driver, Vendor ID : 0x1781, Product ID 0x0E92)

Brontes-IS colorimeter (USBTMC device driver , Vendor ID : 0x1781, Product ID 0x0E97)

When the Brontes-IS colorimeter is connected to the host, it will start the Brontes-IS colorimeter firmware. As soon as the firmware is idle to receive commands, the Power LED goes to the on state.

The firmware updater is a RAW USB device and in order to install this device in Windows, a driver must be installed which is supplied by Admesy. Besides upgrading to new firmware, it is also allowed to downgrade firmware in case this is required. Note that older firmware also may require the use of older software libraries and/or executable versions of software.

The Brontes-IS colorimeter is USBTMC compliant and can be used with libraries that contain a USBTMC compliant driver like NI-VISA. The Brontes-IS colorimeter is a USB 2.0 Full speed device.

In case a USB host is detected, it is assumed that the Brontes-IS colorimeter operates only via USB. This means that RS232 is not functional. Triggering via USB is allowed, but needs to be enabled via software.

### 4.2 RS232

Brontes commands are equal for all interfaces. Note that for high speed transfers it is best to use USB.

## 5 Device drivers

### 5.1 USB

Since the Brontes-IS is an USBTMC device, drivers exists for many platforms and processor architectures. The following table provides an overview of these platforms.

Driver name →	NI-VISA	Libusb	Native kernel driver	Agilent USBTMC
Windows 98	untested	untested	not available	untested
Windows NT	untested	untested	not available	untested
Windows XP	☑	☑	not available	untested
Windows VISTA	☑	☑	not available	untested
Windows CE	untested	untested	not available	untested
Apple OSX PPC	☑	untested	not available	unknown
Apple OSX Intel	☑	untested	not available	unknown
Linux i386 (32bit)	☑	☑	Kernel >= 2.6.28	☑
Linux i386 (64bit)	32bit mode	☑	Kernel >= 2.6.28	☑
Linux ARM	not available	☑	Kernel >= 2.6.28	☑
Linux other	not available	☑	Kernel >= 2.6.28	☑

Untested : Available, but not tested by Admesy.

Native kernel driver : Driver included with the operating system

Admesy supports all tested platforms but does not provide standard applications on all platforms. The above matrix is provided to show the possible platforms for software development.

### 5.2 RS232

When no USB driver is available or the host system does not provide USB, RS232 can be used as it does not require additional drivers for the Brontes-IS colorimeter.

## 6 Command set description

The functions of the colorimeter can be best described via the following categories :

- System commands
- Configuration commands
- Measurement commands
- Trigger programming commands

The Brontes-IS colorimeter uses SCPI like commands for control and measurement. These are ASCII based commands and follow specific rules regarding syntax. Although the Brontes-IS colorimeter uses SCPI like commands, they deviate from the SCPI standard.



## 6.1 Command structure

Every command starts with a colon “:”, which identifies the root of the command tree. Each further keyword is also separated a colon. In case parameters need to be specified, the last keyword and parameters are separated by a single space character. In case more than one parameter needs to be specified, the parameters need to be separated by a comma.

The command tables show commands in long and short format. The short format is specified by upper case characters. It is allowed to use long and short format or a mixed format. Optional keywords are shown between brackets [...]. Commands are case insensitive, so it is allowed to use both or a mix of upper and lower case.

The command structure is valid for all communication interfaces of the Brontes-IS colorimeter.

Example commands :

Command table syntax	Valid command syntax examples	Notes
:SENSe:GAIN auto	:sens:gain auto :sense:gain auto :SENS:gain auto :SENSE:GAIN auto	Sets the GAIN function of the Brontes-IS colorimeter.
:MEASure:XYZ	:measure:XYZ :measure:xyz :meas:XYZ :MEASure:XYZ	The measure commands uses the averaging and gain options.
:SAMPlE:XYZ	:sample:XYZ :sample:xyz :samp:XYZ :SAMPlE:XYZ	With the SAMPLE command, the Brontes colorimeter will perform fast sampling to internal memory. Results are read back from memory after the measurement has been performed.

## 6.2 System commands

The following command can be used to control the Brontes-IS system or read information about the system.

Table 3: System commands

Command syntax	Parameters	Purpose
.*CLS	none	Clear status
.*IDN?	none	Identification Query
.*RST	none	Reset Command
.*STB?	none	Read Status Byte Query (only USB)
.*TST	none	Self-Test Query
.*FWD?	none	Firmware date Query
.*FWT?	none	Firmware time Query
.*SYSTem:VERSion?	none	Get system version information
.*SYSTem:ERRor?	none	Retrieve the last occurred error
.*SYSTem:ERRor:NEXT?	none	Retrieve previous errors.

Table 4: System commands

The Status byte can be used to retrieve information about the status of a command or the system

Return values of the status command can be seen in the table below :

Code	description
0	System is idle
1	Data is available
2	Command processed
4	Data in buffer (should not occur)
8	An error occurred. Use “.*SYSTem:ERRor?” to get the exact error that occurred.

 The \*STB? Command is only available on USB.

### **6.3 Configuration commands**

Configuration commands are used to set parameters of the Brontes-IS colorimeter that are used by the measurement functions.

The settings are used globally by other measurement functions. The selected white standard is used for dominant wavelength calculation.

The gain setting can be varied over 8 stages. The largest gain factor is "1". Results from the Brontes-IS colorimeter include a clip and noise indication which indicate whether the measured light is too bright (clip) or too low (noise). When clipping is detected, the resulting colour will not be correct and a higher gain value should be chosen. When noise is detected, a lower gain value should be chosen. Note that when measuring light from alternating sources, the lowest and highest peaks detected during averaging determine the clip and noise indication levels.



**Table 5: Configuration commands**

Command syntax	parameters	Range	Purpose
:SENSe:GAIN	Gain	0 – 8 (0 = auto)	Set Gain value
:SENSe:GAIN?	none		Returns the current setting.
:SENSe:AVERAge	Averaging (integer)	0 - 4000	Set Averaging value
:SENSe:AVERAge?	none		Query Averaging value
:SENSe:SBW	string	“small”, “wide”, “off”, “user1”, “user2”, “user3”	Set calibration matrix
:SENSe:SBW?	none		Query selected calibration matrix
:CONFigure:MODE	Enum (0,1,2,3)	USB,RS232,STANDALONE_LUM, STANDALONE_DW	Configure the Brontes mode
:CONFigure:MODE?	none	0 - 6	Returns the current setting.
:CONFigure:BAUDRATE	baudrate	0 – 5 (9600 - 230400)	Set RS232 baudrate
:CONFigure:BAUDRATE?	none		Returns the current setting.
:CONFigure:TRIG	Trigger, mode	0 – 1, 0 - 1	Set trigger mode
:CONFigure:TRIG?	none		Returns the current setting.
:CONFigure:WHITE	string	A, B, C, D40, D42, D50, D55, D65, D75, D90, D95, E, F2, F7, F11 (see table 6 for used values)	Set reference white value for dominant wavelength calculation.
:CONFigure:WHITE?	none		Query white reference

Reference white	X	Y	Z
A	109.8405	100.0000	35.5583
B	99.0899	100.0000	85.3242
C	98.0708	100.0000	118.1847
D40	99.6092	100.0000	60.9432
D42	98.7058	100.0000	65.4253
D50	96.3758	100.0000	82.4087
D55	95.6559	100.0000	92.0311
D65	95.0182	100.0000	108.7485
D75	94.9524	100.0000	122.5079
D90	95.2270	100.0000	138.5514
D95	95.3315	100.0000	142.9635
E	100.0000	100.0000	100.0000
F2	99.1869	100.0000	67.3944
F7	95.0392	100.0000	108.7460
F11	100.9631	100.0000	64.3522

**Table 6: White point references**

## 6.4 Measurement commands

Table 5 shows the measurement commands of the Brontes-IS colorimeter. Regarding colour/luminance measurement there are two kind of commands (MEASure/SAMPlE).

The MEASure commands measure the requested values using the set averaging and gain and returns the result in a single structure of three single precision floating point values. Averaging can be set using the :SENSe:AVERage configure command.

The SAMPlE commands measure the requested parameters using a sample count and delay time and return an array of data. The array contains single floating point data. Each sample count equals one complete structure, for example one XYZ structure of data.

Command syntax	Parameters	Range	Purpose
:MEASure:XYZ	none		Measure XYZ
:MEASure:LONG:XYZ	Iterations	1 - 255	Perform multiple :meas:xyz commands and average the resulting data.
:MEASure:Yxy	none		Measure Y and x,y colour point
:MEASure:Yuv	none		Measure Y and u',v' colour point
:MEASure:Fxy	none		Measure flux (lumen) and x,y colour point
:MEASure:FLUX	none		Measure luminous flux (lumen)
:MEASure:LUMIntensity	Light source beam angle		Measure luminous intensity (candela)
:MEASure:Y	none		Measure Y only
:MEASure:DWL	none		Measure dominant wavelength
:SAMPlE:XYZ	Samples, delay	0-4000, 0 - 255	Sample XYZ
:SAMPlE:Yxy	Samples, delay	0-4000, 0 - 255	Sample Yxy
:SAMPlE:Yuv	Samples, delay	0-4000, 0 - 255	Sample Yuv
:SAMPlE:Y	Samples, delay	0 - 24000, 0 - 255	Sample Y channel (in counts, uncalibrated)
:MEASure:TEMPerature	none		Measure temperature of Sensor head and CPU

Table 7: Measurement commands

### Notes :

- 1) The delay time is set in sample times, meaning a delay of one will skip one sample.
- 2) When using high sample amount make sure timeout values in the application software are set accordingly.

## 6.5 User EEPROM commands

The following commands can be used to store values in the user EEPROM space. Note that they are not stored until a :EEPROM:WRITE command is given. It is advised to reboot the Brontes-IS after writing new values to the EEPROM.

Command syntax	Parameters	Range	Purpose
:EEPROM:STARTUP:READ	none		Copies startup conditions from eeprom to internal variables. Values can than be read using :SENSe:AVERAge? for example.
:EEPROM:STARTUP:WRITE	Brontes mode, amp factor	0 – 6 , 0 -8	Copies internal variables to eeprom and sets mode and amp factor.
:EEPROM:LUM:READ	range	1 - 15	Read luminance range of stand alone mode
:EEPROM:LUM:WRITE	Range, value	1 – 15, value(float)	Write luminance values for stand alone mode
:EEPROM:DW:READ	DWL index	0 - 14	Read DWL of stand alone mode.
:EEPROM:DW:WRITE	DWL index, DWL, deviation	0 - 255	Write DWL of stand alone mode.
:EEPROM:SBW:READ	User matrix, index1, index2	0 - 2 , 0 – 2, 0 – 2	Read user calibration matrix
:EEPROM:SBW:WRITE	User matrix, index1, index2, Value	0 - 2 , 0 – 2, 0 – 2 , float	Write user calibration matrix
:EEPROM:WRITE	none	0-4000, 0 - 255	Write all settings to EEPROM. This command fixes the eeprom values.
:EEPROM:READ:SN	None		Reads the serial number.

## 6.6 Returned results

:MEASure command return their result in ASCII formated floating point as shown below :

(X,Y,Z,clip,noise) → %f,%f,%f,%d,%d\n  
(X,Y,Z can be substituted for L,a,b or other colour spaces).

:SAMPlE command return all measurement data also in ASCII format. The first three values indicate the delta time between samples and the clip and noise values.

dt	%f\n
clip	%f\n
noise	%f\n
Value1	%f\n
Value2	%f\n
Value3	%f\n

Exceptions to the above are the :MEASure:TEMPerature , :MEAS:Y and :SAMPlE:Y commands.

:MEASure:TEMPerature → (MCU temperature, Sensor temperature) → %f,%f\n

:SAMPlE:Y returns it's data in unsigned integer format.

dt	%u\n
clip	%u\n
noise	%u\n
Value1	%u\n
Value2	%u\n
Value3	%u\n

:MEAS:Y -> (Y in counts ) → %u\n

 : In RS232 mode the SAMPLE command separate the values using a TAB (t) and the last value is terminated using an end of line constant (\n).

## 7 Measurement example

The Brontes-IS uses default settings when the device is started. These can be programmed by the end user so that the device starts with the same settings each time it is connected.

Although it's possible to program all Brontes-IS devices in a production environment to start with equal settings, it is recommended to set the averaging, gain and SBW values in the initialization routine of the host software.

A typical measurement example of XYZ would include the following commands :

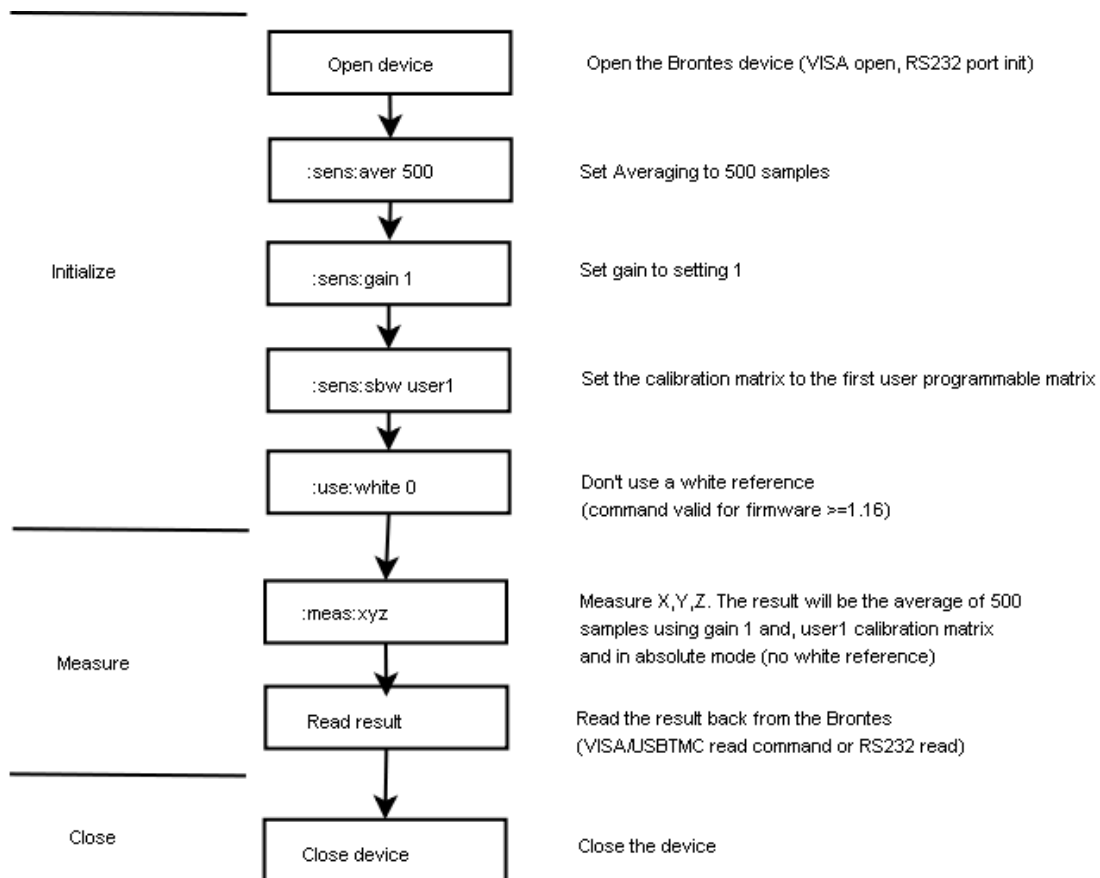

## 8 Brontes-IS formulas.

The Brontes-IS colorimeter uses an XYZ sensor, meaning that other colour spaces are being converted from XYZ. The following sections show the mathematical conversions that are used by the Brontes colorimeter to perform conversion from XYZ to other colour spaces.

### 8.1 XYZ to Yxy conversion

$$x = \frac{X}{(X+Y+Z)}$$

$$y = \frac{Y}{(X+Y+Z)}$$

$$z = \frac{Z}{(X+Y+Z)} = 1 - x - y$$

### 8.2 XYZ to CIE 1976 UCS Yu'v' conversion

Note : u'v' is noted without the hyphen in the Brontes commands. All Yuv commands perform CIE Yu'v' calculations.

$$u' = \frac{4X}{(X+15Y+3Z)}$$

$$v' = \frac{9Y}{(X+15Y+3Z)}$$

### 8.3 XYZ to Luminous flux ( Φ )

$$\Omega_{sphere} = \pi * \left( \sin \left( \frac{13.5 * \pi}{180} \right) \right)^2$$

$$A = \pi (0.011)^2$$

$$\Phi = Y * A * \Omega_{sphere}$$

### 8.4 XYZ to Luminous intensity ( I )

$$\Omega_{source} = 2 * \pi * \left( 1 - \cos \left( \frac{\omega_{radians}}{2} \right) \right)$$

$\omega_{radians}$  is light source beam angle.

$$I = \frac{\Phi}{\Omega_{source}}$$

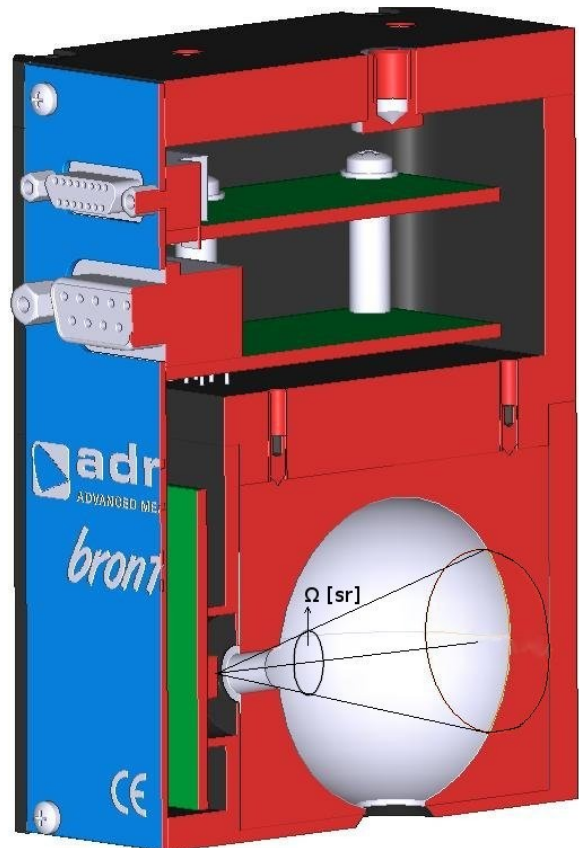

## 9 Operating modes

Operation is possible as slave device for a host PC or as stand alone device. In slave mode the Brontes-IS colorimeter listens to commands send by the host PC as mentioned in the previous paragraphs.

The modes of the Brontes-IS are :

- 1) USB mode
- 2) RS232 mode
- 3) Stand alone modes :
  - Measure luminance and fit into 15 programmed levels.
  - Measure colour and match the closest dominant wavelength (15 categories).

In all modes, USB is still active but when only USB is used, it is recommended to set it to USB mode so that the Brontes-IS responds in the fastest possible way to commands.

The operating mode must be selected via the Brontes-IS PC application. All target values can be measured using the configuration utility or input manually.

Once the USB cable is connected, the Brontes-IS will automatically leave the stand alone mode and listen to USB communication. In stand alone mode, power should be connected via the dedicated 9V power input or via the 9V input of the GPIO connector.

In stand alone mode, trigger in -and output can be enabled to synchronize for the highest possible speed. Typical a speed of over 1000 measurement per second can be reached (averaging < 5), which allows extreme fast sorting applications.

## 10 Typical spectral sensitivity

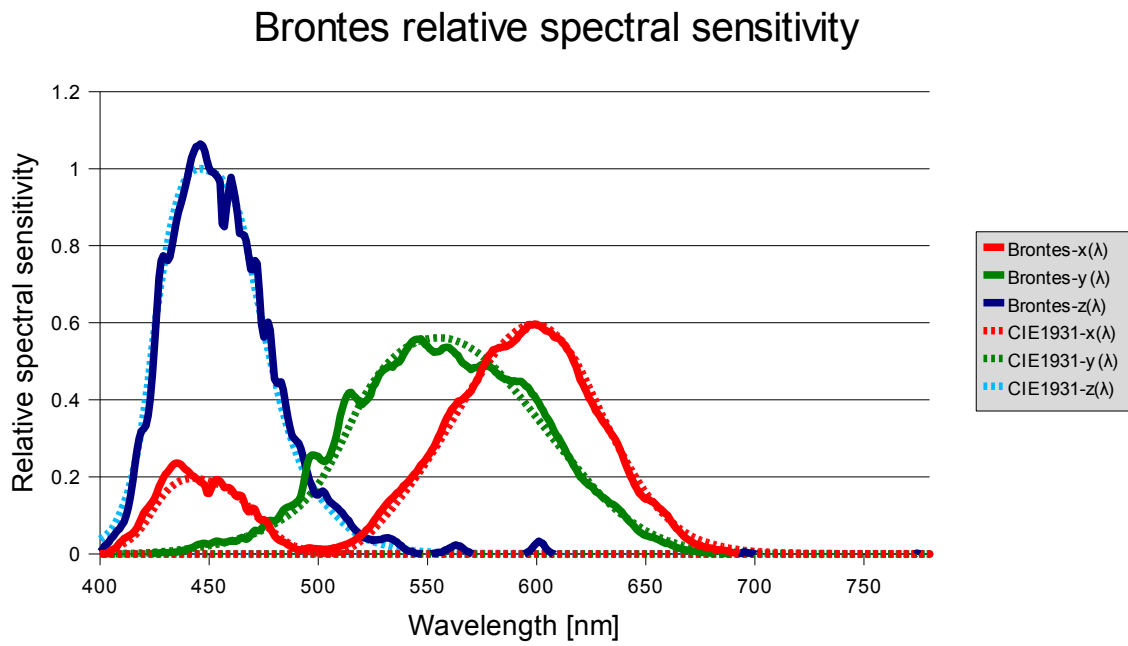

# 11 Mechanical drawing (mounting holes)

