

Measuring according the human eye at high speed.



- Absolute colour measurement according to the human eye (CIE1931).
- High speed measurement (18000 luminance measurements per second, 5500 colour measurements per second).
- Measure colour point and luminance in various colour spaces (XYZ, Yxy, CIELab, Yuv, LCH etc...).
- Trigger input for in line applications. General Purpose I/O for control.
- Direct measurement or through fiber optics.
- Measure via a PC (also embedded) or stand alone mode.
- Windows, Linux and MAC OSX compatible.
- SCPI command interface for easy integration in other applications.
- Directly supported in Labview / Labwindows / Visual Studio via VISA library. Other programming languages that support VISA can be used.
- USBTMC standard compliant.

Interfaces

USB 2.0	USBTMC compliant, SCPI command set, Full speed device
I ² C	For embedded purposes, using the same command set as USB.
RS232	For PC and embedded purposes, using the same command set as USB.
I/O	4 lines 3.3V general purpose I/O
Trigger input	3.3V compliant , Absolute maximum rating 5.8V.

Power ratings

	Min voltage	Typical voltage	Max voltage	Consumption
USB powered	4.75V	5.00V	5.25V	Typical 50mA
DC-adapter powered	8.50V	9.00V	15.00V	Typical 50mA
GPIO powered	8.00V	9.00V	15.00V	Typical 50mA

Mechanical dimensions

Height, Width, depth	50x50x100 mm
Mounting	¼ BSW (fits ¼ UNC) mount on bottom plate, 4xM4 threat holes on bottom plate, 4xM4 threat holes on front.

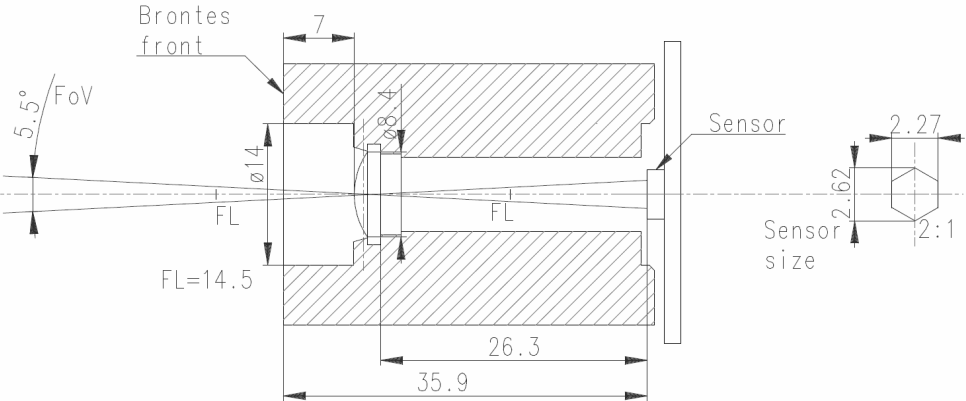
Measurement system													
Photo detector	Silicon Photo diode using XYZ interference filter												
Spectral response	Approximates CIE 1931 colour matching functions (see spectral response graph on last page)												
Colour systems	XYZ, Yxy, Yuv, Lab, Luv, correlated colour temperature, dominant wavelength.												
Optical system	<p>Enclosed lens system – Direct measurement</p> 												
Measurement spot size (angle of acceptance)	<p>35° angle of acceptance, other angles can be applied on request.</p> <table border="1"> <tr> <td>Distance to front of colorimeter</td> <td>0mm</td> <td>15mm</td> <td>25mm</td> <td>50mm</td> <td>75mm</td> </tr> <tr> <td>Measurement spot size</td> <td>4.5mm</td> <td>14mm</td> <td>20mm</td> <td>36mm</td> <td>52mm</td> </tr> </table>	Distance to front of colorimeter	0mm	15mm	25mm	50mm	75mm	Measurement spot size	4.5mm	14mm	20mm	36mm	52mm
Distance to front of colorimeter	0mm	15mm	25mm	50mm	75mm								
Measurement spot size	4.5mm	14mm	20mm	36mm	52mm								
Measurement speed	Luminance at 18,000 samples/second , Colour measurement at 5,500 points/second (at 16bit for X, Y, Z).												

Colorimeter specification

Parameter	Range	Accuracy	Repeatability
Resolution	16bit for X, Y and Z	>60dB without averaging for X, Y, Z	
Luminance (Y)	0.05 cd/m ² –500,000 cd/m ² 8 gain stages, including auto ranging function	±4% of measured value	±0.1%
Chromaticity : x,y	Approximates CIE1931 colour matching functions	±0.001 absolute at equal energy point (x,y = 0.333)	x,y : ±0.001 for Y > 2 cd/m ² * x,y : ±0.0002 for Y > 10 cd/m ² *
			* averaging 5 samples, approximately 1ms.
CR measurement	> 10,000,000	±5%(depending on lowest Y value)	±5%(depending on lowest Y value)
Switching time	>0.1ms	±5%	
Speed	Luminance : Max 18kHz sampling Colour : Max 5.5kHz sampling		
Flicker (Contrast Method)	>0.05% at 50% Luminance level at every gain stage.	±0.2% at 50% luminance level.	±0.2%
Flicker (JEITA method)	>0.05% at 50% Luminance level at every gain stage.	±0.2% at 50% luminance level.	±0.2%
Operating Temperature	0-40°C Measurement at other temperatures possible via fibre optics.		

Brontes relative spectral sensitivity

